

Transit System Demonstration Model

Sponsor: Intelligent Transportation – www.intelligenttransportation.com

Sponsor's General Mission or Business Statement: To focus on the value and quality of personal mobility to help open social, educational, economic and conservational opportunities.

Sponsor's Advisor, Title, and Phone Number: Bill James, Mechanical Engineer, (612) 414-4211

Sponsor's Address: 15632 Alpine Circle, Burnsville, MN 55306

University of St. Thomas School of Engineering Academic Advisor: Professor Mike P. Hennessey

Team Member Names: John Sustar (EE), Henrik Impola (ME), Nathan Hildebrand (ME), Holly Kimball (ME)

Senior Design Clinic I-II (ENGR 480-1) 2005-6 Project Mission Statement: Design and build a demo model of the Intelligent Transportation System without the car attached. This will consist of nine feet of track and the superstructure assembly which includes a drive motor, wheels, trolley, computer and software to run system.

Major Design Requirements:

1. Move trolley across beam
2. Must be portable system
3. Must be aesthetically pleasing
4. Hard stop in place for Motor
5. Off shelf availability of parts
6. Battery Operated

Senior Design Project Summary: During the Fall 05 and Spring 06 semesters, the student members of Team Intelligent were tasked with the building a demonstration model of a Jpod transit system, with the design requirement listed above. The first stage of the project was determining the sponsor's desired system and researching similar systems within the realm of Personal Rapid Transit. After multiple meetings, efforts were placed on system design. Once calculations were obtained, software analysis on system was preformed and approximate cost determined, the results were presented to Bill James. Previously obtained items from the client became available to be used. The designs were adjusted accordingly and items were purchased. Mechanical fabrication and electrical functional testing became the groups focus during the spring semester. SolidWorks modeling package was used in initial design as well as final product. The final design completed a demonstration model to control the movement of a Jpod car.

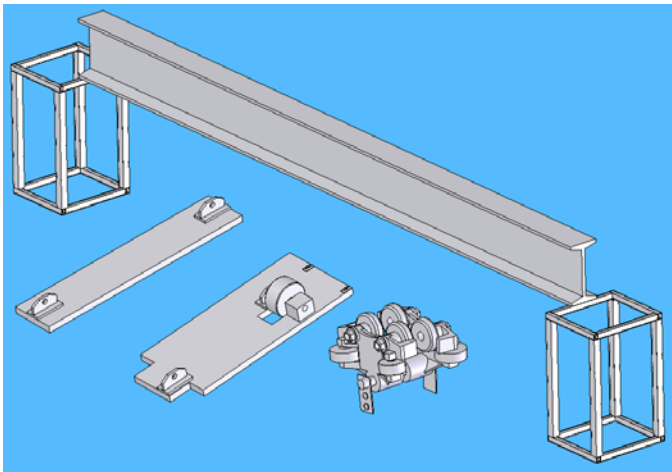

CAD Design



Demonstration Model