

## Ergonomic and Efficient Grille Application

**Sponsor:** Andersen Corporation  
**Sponsor's Vision:** To lead the window and door industry by creating products and services that are different and better as measured by their customers.  
**Sponsor's Advisor:** Joshua J. Charland, Engineer, 651-264-2030  
**Sponsor's Address:** 100 Fourth Avenue North, Bayport, MN 55003-1096  
**UST Advisor:** Dr. Michael P. Hennessey  
**Team Members:** Jeffrey Delesha (EE), Adam Runnoe (ME), Melissa Sawyer (EE), Madeline Tingstad (ME)  
**Project Mission:** Design, test, and construct an ergonomic and efficient grille application process for Andersen Corporation's in-swing patio door production line.

### Major Design Requirements:

1. Improve ergonomics of applying grilles to patio doors
2. Maintain or reduce cycle time
3. Apply a minimum of 15psi to grilles
4. Conform to currently in place assembly line
5. Complete project within \$5000 budget
6. Accommodate for four different door sizes
7. Comply with Andersen machine and lubrication standards



**Project Summary:** The final design is comparable to an old style wringer clothing dryer and applies a minimum of 15 PSI to the interior and exterior grilles, meeting adhesion specifications. Two turrets of four rollers of varying widths (to accommodate four standard door sizes) each of A40 shore hardness urethane are used as nip rollers to apply pressure. Pressure is applied to the roller turrets by air actuators and the bottom rollers are motorized to help drive the door through the turret system. Our test results at Saint Thomas consistently show smooth operation and application of at least 15 PSI to the grille adhesive. Using this design allows grilleing of the interior and exterior faces of the door at the same time, thus reducing cycle time. During the fall semester Team Andersen conceived of the design, ordered test rollers and pressure sensing film, built a test apparatus and tested the rollers to find out how much force would need to be applied to obtain 15 PSI evenly across all the grilles. Spring semester was busy with finalizing the design in SolidWorks (a CAD program), ordering parts, and final assembly and testing. Successful completion of the project required knowledge of steel construction, urethane products, drive roller concepts, and air actuation systems. We hope to install our design at Andersen following the Senior Design Show and are excited to relieve the production line workers of the burden of hand-rolling the grilles onto the doors.

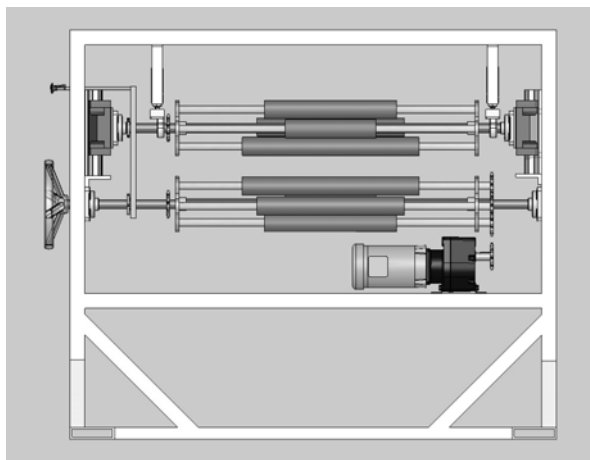

Figure 1: Front View of Final Design

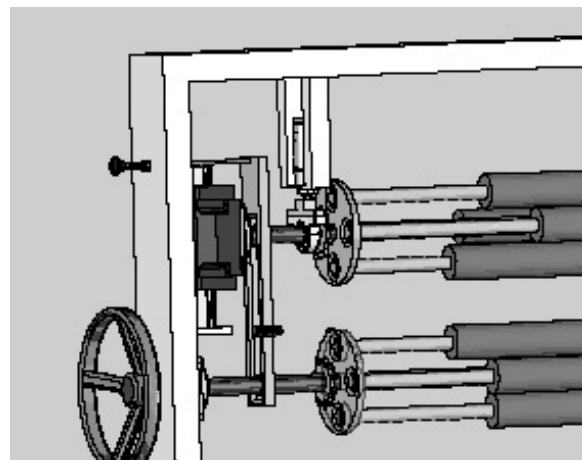

Figure 2: Close-up of Final Design